

Specifications

Concrete: Minimum Compressive Strength is 5,000 PSI @ 28 Days.

Reinforcing: Primary reinforcement will be cover, side and bottom- #3 and #4 Rebar (Grade 60).

Sealant: Butyl Sealant used in the seam of the tank and risers will meet or exceed ASTM C990.

Inlet Opening: 4" Diameter- Standard
Outlet Opening: 4" Diameter- Standard

Both openings are fitted with a Pipe-to Structure Resilient Connector which meets or exceeds ASTM C1644.

Earth Cover: Maximum Depth of Bury 8'.

Design Data: Design per ASTM C1227. Tank is Traffic Rated (H-20).

Installation: There shall be a minimum bedding of 4" of washed sand or stone less than 1" in size in soil terrain and 8" bedding in rock terrain. Backfilling around tanks with material describe above is suggested when cover is 4' or greater.

Tank Warranty: All tanks are warranted against defective materials and / or workmanship for One year from the date of delivery when installed with manufacturer's instructions. Should a defect appear within the warranty period, Lake Shore Burial Vault Company will supply a new tank in replacement thereof. Lake Shore Burial Vault Company's liability is limited to the value of the tank itself and specifically excludes the cost of installation and/or removal and any subsequent damages. Failure to follow installation procedures and general notes will void the warranty.

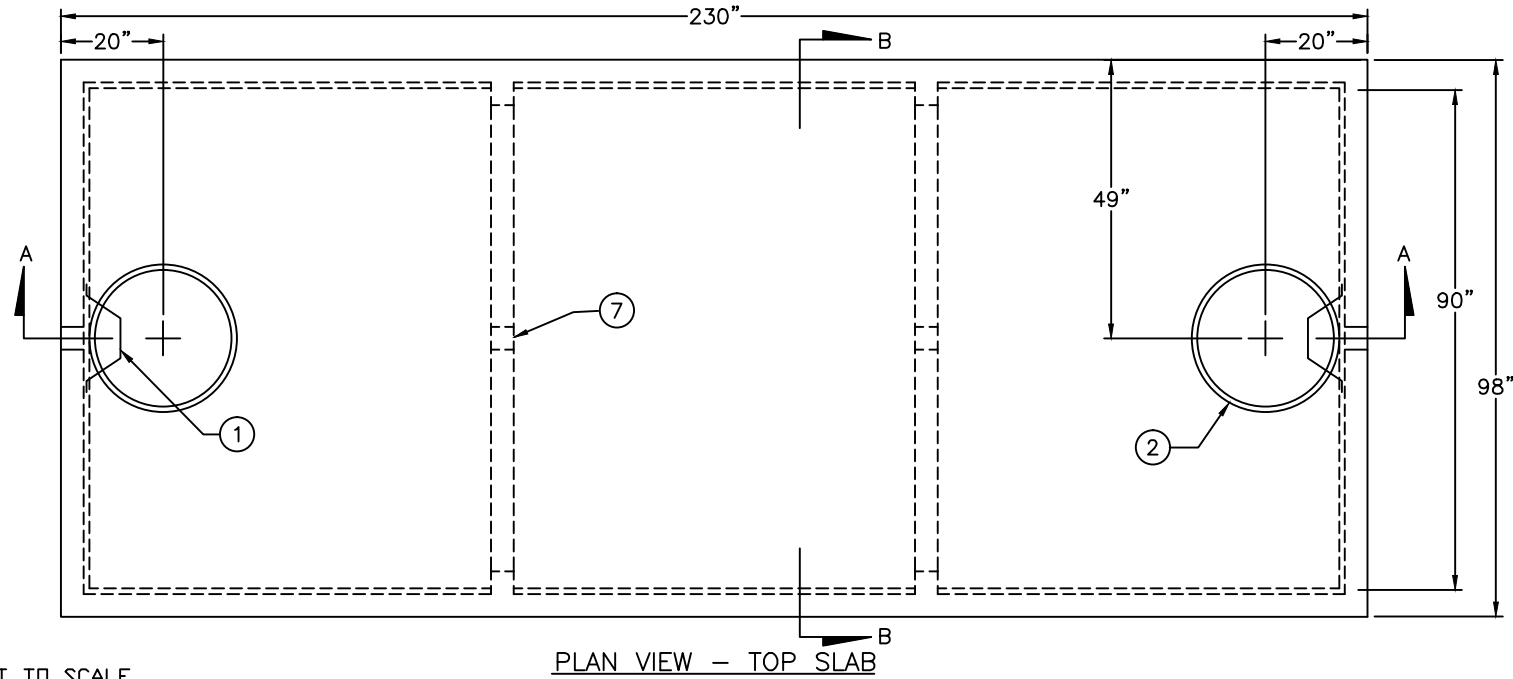
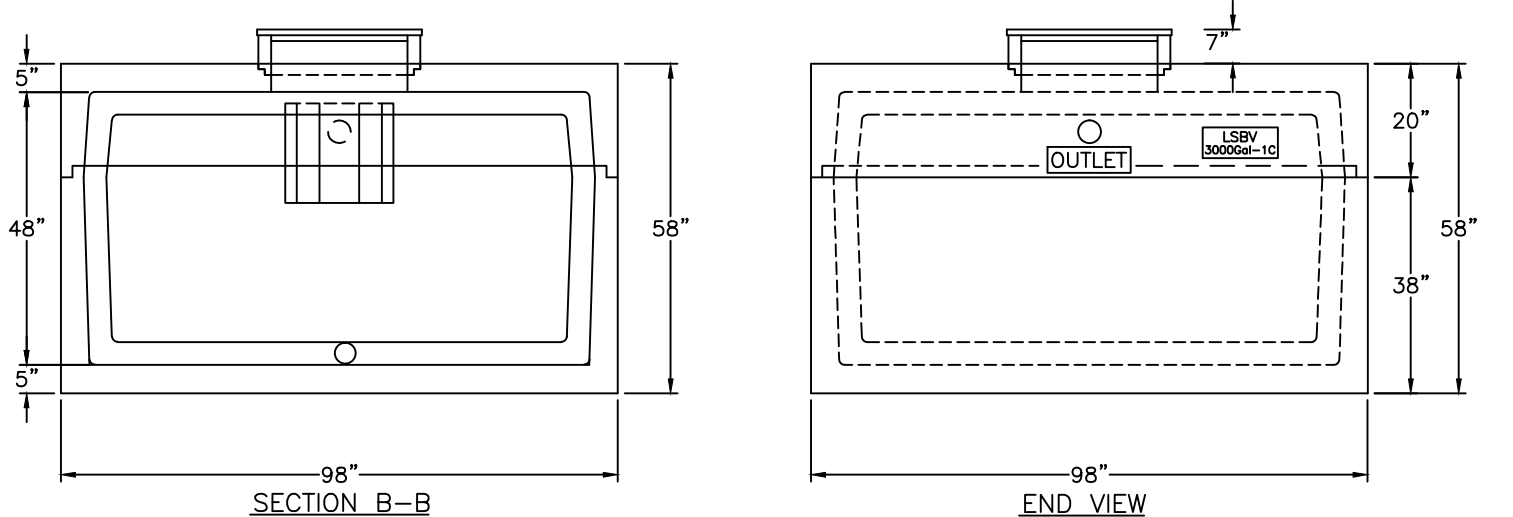

NOT TO SCALE

Lake Shore Burial Vault Co., Inc
 12780 W. Lisbon Road
 Brookfield, WI 53005
Phone: 262.781.6262 **Fax:** 262.781.6280
 www.lsburialvaults.com

General Notes:

This drawing is the property of Lake Shore Burial Vault Company and shall not be copied or submitted without the consent of this company. All vertical measurements are accurate within +/- 1" on the tank.

Model: 3,000 Gallon LP, Septic, Holding, Pump Tank

Drawn By: TMQ **Date:** 6/6/2016 **Septic Tank:** 3,370 Gal. **GPI:** 86.49
Holding Tank: 3,545 Gal.

Approx Weight: 13,920 lbs - T
 19,680 lbs - B **Dwg. No:** 03000.00S (1 of 2)

Specifications

Concrete: Minimum Compressive Strength is 5,000 PSI @ 28 Days.

Reinforcing: Primary reinforcement will be cover, side and bottom- #3 and #4 Rebar (Grade 60).

Sealant: Butyl Sealant used in the seam of the tank and risers will meet or exceed ASTM C990.

Inlet Opening: 4" Diameter- Standard
Outlet Opening: 4" Diameter- Standard

Both openings are fitted with a Pipe-to Structure Resilient Connector which meets or exceeds ASTM C1644.

Earth Cover: Maximum Depth of Bury 8'.

Design Data: Design per ASTM C1227. Tank is Traffic Rated (H-20).

Installation: There shall be a minimum bedding of 4" of washed sand or stone less than 1" in size in soil terrain and 8" bedding in rock terrain. Backfilling around tanks with material describe above is suggested when cover is 4' or greater.

Tank Warranty: All tanks are warranted against defective materials and / or workmanship for One year from the date of delivery when installed with manufacturer's instructions. Should a defect appear within the warranty period, Lake Shore Burial Vault Company will supply a new tank in replacement thereof. Lake Shore Burial Vault Company's liability is limited to the value of the tank itself and specifically excludes the cost of installation and/or removal and any subsequent damages. Failure to follow installation procedures and general notes will void the warranty.

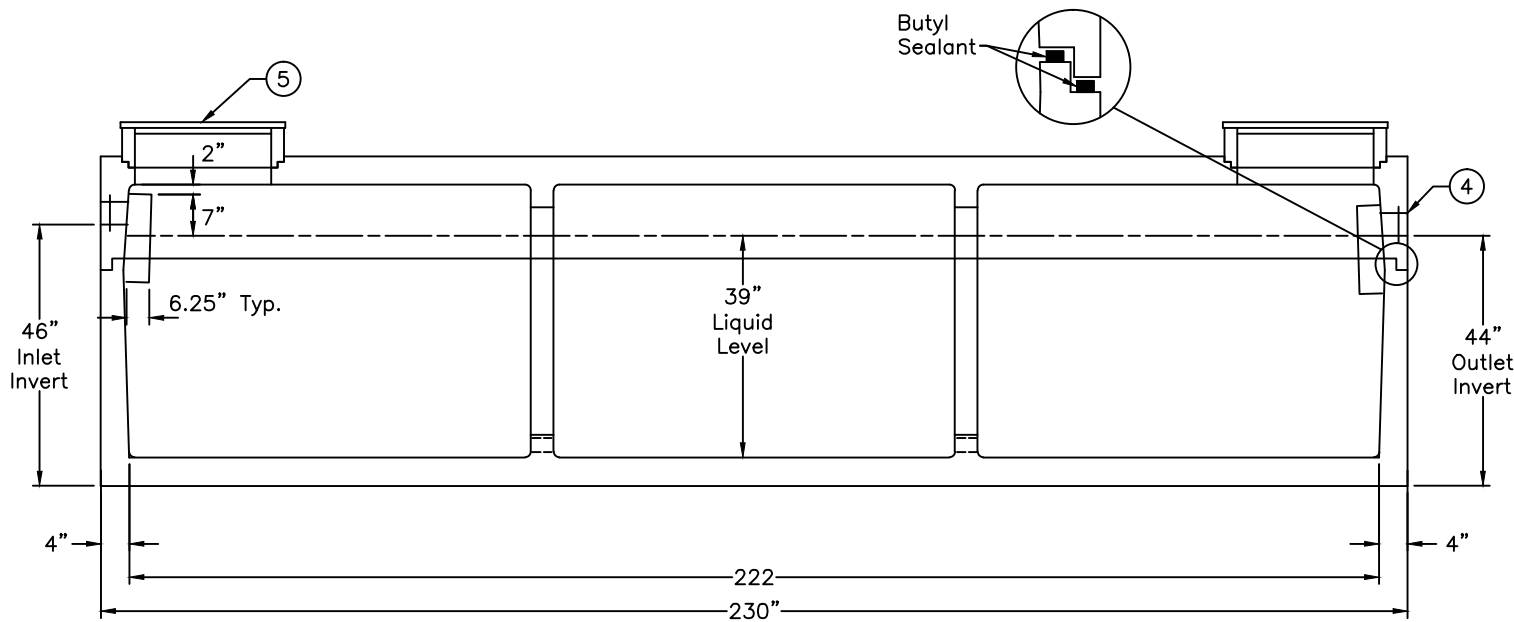

SECTION A-A

Item No	Description
1	Tank Baffle- HDPE
2	Riser - 24" Dia.
3	Boss Stop
4	4" Dia. Resilent Connector
5	Manhole Cover
6	Tank Baffle - PVC
7	4" Dia. Pass- Thru

NOT TO SCALE

Lake Shore Burial Vault Co., Inc
12780 W. Lisbon Road
Brookfield, WI 53005
Phone: 262.781.6262 **Fax:** 262.781.6280
www.lsburialvaults.com

General Notes:

This drawing is the property of Lake Shore Burial Vault Company and shall not be copied or submitted without the consent of this company. All vertical measurements are accurate within +/- 1" on the tank.

Model: 3,000 Gallon LP, Septic, Holding, Pump Tank

Drawn By: TMQ **Date:** 6/6/2016 **Septic Tank:** 3,370 Gal. **GPI:** 86.49
Holding Tank: 3,545 Gal.

Approx Weight: 13,920 lbs - T
19,680 lbs - B **Dwg. No:** 03000.00S (2 of 2)